

LCD 400

Category I or Category III Appliance
(see Installation and Operation Manual for venting information)

CODE OPTIONS

CSD-1	UTC Lockout/Reset Control Manual Reset LWCO
--------------	--

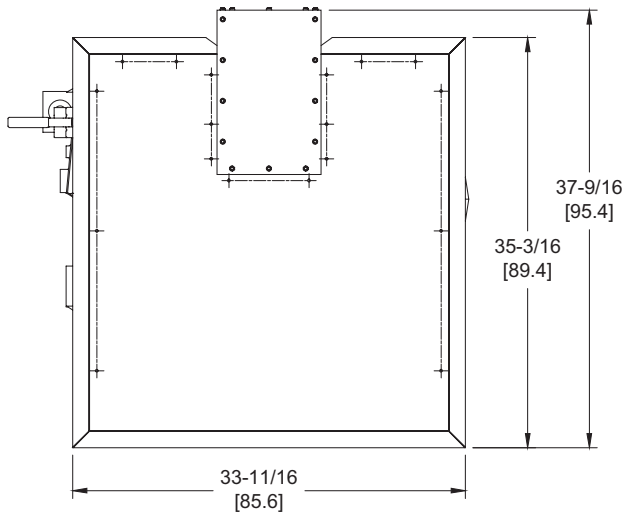

OUTDOOR TOP VIEW

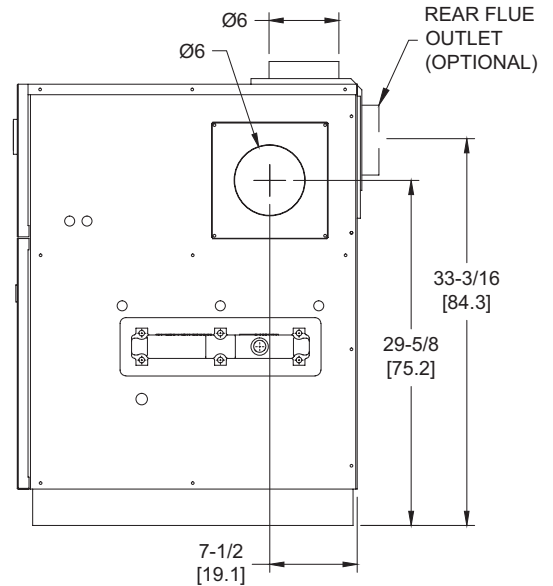

RIGHT VIEW

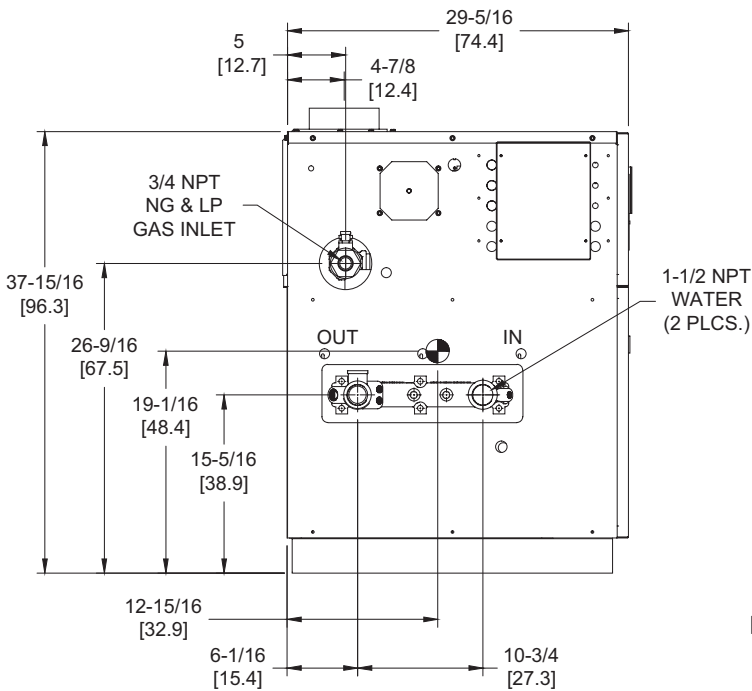

LEFT VIEW

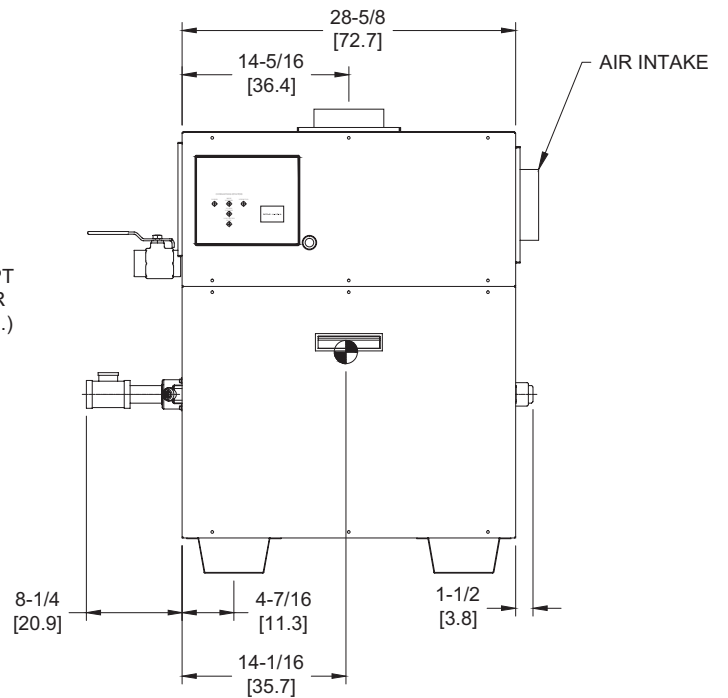

FRONT VIEW

RSUB-15-F

LCD 400 model water heater not available for sale in the U.S. market due to DOE regulations.

Notes:

1. Dimensions are approximate and should not be used to "rough-in" equipment.
2. Dimensions are subject to change without notice.
3. All dimensions are in inches (cm).
4. Symbol indicates center of gravity.

BOILER CERTIFIED RATINGS & CAPACITIES

Fuel Type	Natural/Propane Gas	Boiler FLA	3.8*
Input BTU/hr.	399,000 / 117 kW	Min. Gas Pressure Required	7" WC**
Output BTU/hr.	327,180 / 96 kW	Max. Gas Pressure Allowed	14" WC
Electrical Requirements	120VAC/ 1 ph/ 60 hz	Operating Weight	402 lbs. / 183 kg.

BOILER / WATER HEATER TRIM & CONTROLS

Main Gas Valve	Honeywell VR8305Q 3/4"	Pilot Valve	Honeywell VR8205Q
Firing Valve	Honeywell B200T1025 3/4"	Air Switch	Cleveland RSS-495
Ignition Control	UTC 1003-61A	Blower Motor	1/5 hp - FLA 3.0
Operating Control (LB/LW)	Jumo	Relief Valve - LW	3/4" x 3/4" set @ 125 psi
High Limit (LB/LW)	Jumo	Relief Valve - LB	3/4" x 3/4" set @ 50 psi
		Flow Switch	TACO

A.S.M.E.

ASME Sect IV Htg Surface	40.1 Sq. Ft. / 3.73 Sq. M.	Design Data	Max. 160 psig & 250°F
Water Volume	1.4 gal / 5.3 Liters		

* Add circulator amps.

** For incoming gas pressures lower than 7" WC natural or 11" WC propane, consult factory.

BOILER TEMPERATURE RISE / PRESSURE DROP

15°F / 8.3°C				20°F / 11.1°C				25°F / 13.9°C			
Flow Rate		Pressure Drop		Flow Rate		Pressure Drop		Flow Rate		Pressure Drop	
GPM	L/s	Ft	kPa	GPM	L/s	Ft	kPa	GPM	L/s	Ft	kPa
43.7	2.8	0.70	2.1	32.8	2.1	0.41	1.2	26.2	1.7	0.27	0.8

WATER HEATER HOURLY RECOVERY CAPACITY (GPH & LPH)

40°F	22°C	60°F	33°C	80°F	44°C	100°F	56°C	120°F	67°C	140°F	78°C
982	3717	655	2478	491	1859	393	1487	327	1239	281	1062

<p>REP FIRM _____</p> <p>SUBMITTED BY _____</p> <p>JOB NAME _____</p> <p>ARCHITECT _____</p> <p>ENGINEER _____</p> <p>CONTRACTOR _____</p> <p>DATE _____</p>	<h1 style="margin: 0;">LCD 400</h1> <p>Category I or Category III Appliance (see Installation and Operation Manual for venting information)</p>  <p>RBI® A Division of Mestek, Inc. Westfield, MA 01085 (413) 564-5515</p> <p><small>RELIABLE. BOLD. INNOVATIVE.</small></p>
---	--

LCD 600

Category I or Category III Appliance

(see Installation and Operation Manual for venting information)

CODE OPTIONS

CSD-1

UTC Lockout/Reset Control
Manual Reset LWCO

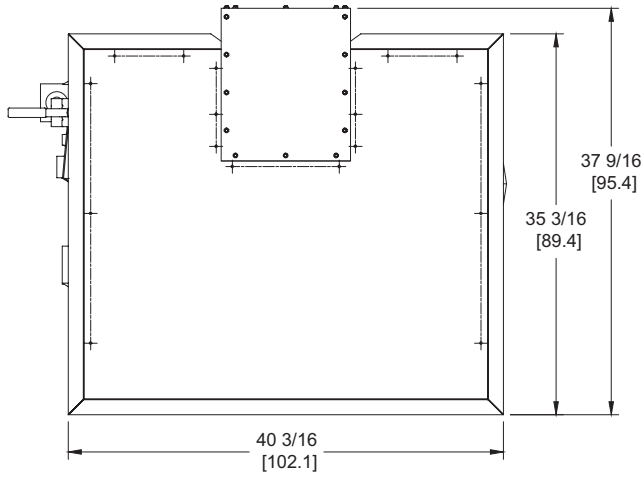

OUTDOOR TOP VIEW

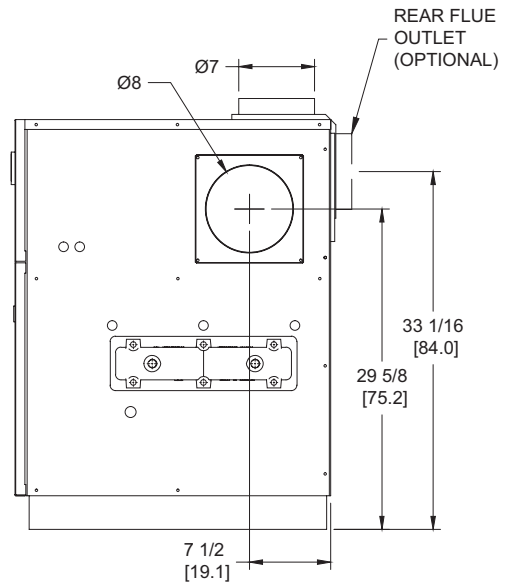

RIGHT VIEW

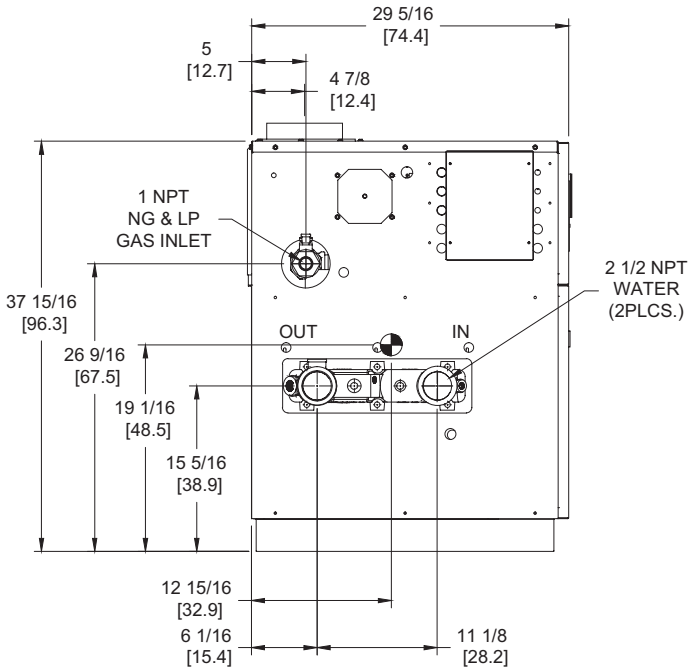

LEFT VIEW

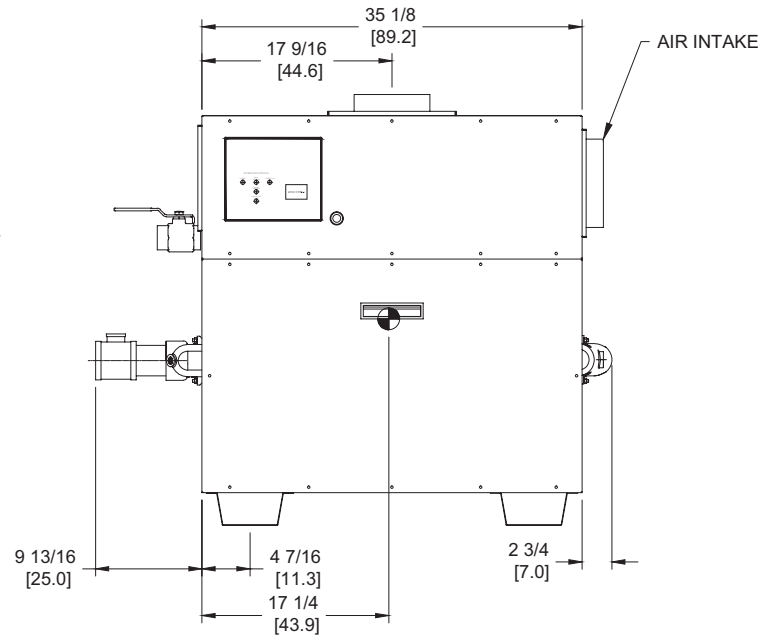

FRONT VIEW

Notes:

1. Dimensions are approximate and should not be used to "rough-in" equipment.
2. Dimensions are subject to change without notice.
3. All dimensions are in inches (cm).
4. Symbol indicates center of gravity.

RSUB-16-F

BOILER CERTIFIED RATINGS & CAPACITIES

Fuel Type	Natural/Propane Gas	Boiler FLA	3.8*
Input BTU/hr.	600,000 / 176 kW	Min. Gas Pressure Required	7" WC**
Output BTU/hr.	492,000 / 144 kW	Max. Gas Pressure Allowed	14" WC
Electrical Requirements	120VAC/ 1 ph/ 60 hz	Operating Weight	523 lbs. / 237 kg.

BOILER / WATER HEATER TRIM & CONTROLS

Main Gas Valve	Honeywell V8944B 1"	Pilot Valve	Honeywell VR8205Q
Firing Valve	Honeywell B200T1033 1"	Air Switch	Cleveland RSS-495
Safety Valve	Honeywell V48A 1"	Blower Motor	1/4 hp - FLA 3.0
Ignition Control	UTC 1003-61A	Relief Valve - LW	3/4" x 3/4" set @ 125 psi
Operating Control (LB/LW)	Jumo	Relief Valve - LB	3/4" x 3/4" set @ 50 psi
High Limit (LB/LW)	Jumo	Flow Switch	TACO

A.S.M.E.

ASME Sect IV Htg Surface	51.3 Sq. Ft. / 4.77 Sq. M.	Design Data	Max. 160 psig & 250°F
Water Volume	1.6 gal / 5.9 Liters		

* Add circulator amps.

** For incoming gas pressures lower than 7" WC natural or 11" WC propane, consult factory.

BOILER TEMPERATURE RISE / PRESSURE DROP

15°F / 8.3°C				20°F / 11.1°C				25°F / 13.9°C				30°F / 16.7°C			
Flow Rate		Pressure Drop		Flow Rate		Pressure Drop		Flow Rate		Pressure Drop		Flow Rate		Pressure Drop	
GPM	L/s	Ft	kPa	GPM	L/s	Ft	kPa	GPM	L/s	Ft	kPa	GPM	L/s	Ft	kPa
65.6	4.1	1.84	5.4	49.2	3.1	1.08	3.2	39.4	2.5	0.71	2.1	32.8	2.1	0.51	1.5

WATER HEATER HOURLY RECOVERY CAPACITY (GPH & LPH)

40°F	22°C	60°F	33°C	80°F	44°C	100°F	56°C	120°F	67°C	140°F	78°C
1477	5582	984	3721	738	2791	591	2233	492	1861	422	1595

<p>REP FIRM _____</p> <p>SUBMITTED BY _____</p> <p>JOB NAME _____</p> <p>ARCHITECT _____</p> <p>ENGINEER _____</p> <p>CONTRACTOR _____</p> <p>DATE _____</p>	<h1 style="margin: 0;">LCD 600</h1> <p style="margin: 5px 0;">Category I or Category III Appliance (see Installation and Operation Manual for venting information)</p> <div style="display: flex; align-items: center; justify-content: center; margin-top: 20px;">  <div style="margin-left: 10px;"> <p>A Division of Mestek, Inc. Westfield, MA 01085 (413) 564-5515</p> </div> </div> <p style="font-size: small; margin-top: 5px;">RELIABLE. BOLD. INNOVATIVE.</p>
---	---

LCD 750

Category I or Category III Appliance

(see Installation and Operation Manual for venting information)

CODE OPTIONS

CSD-1

UTC Lockout/Reset Control
Manual Reset LWCO

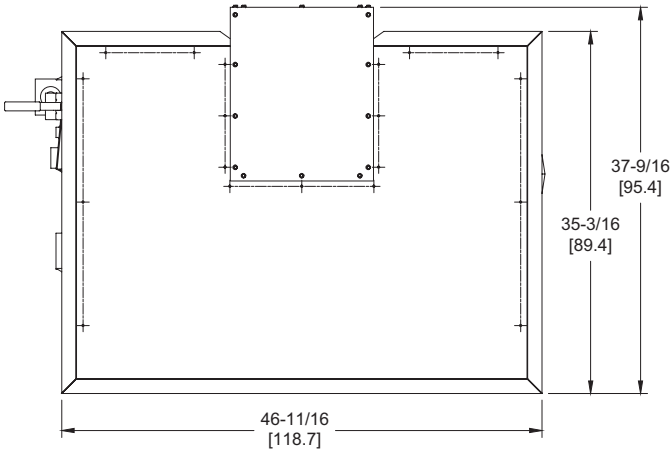

OUTDOOR TOP VIEW

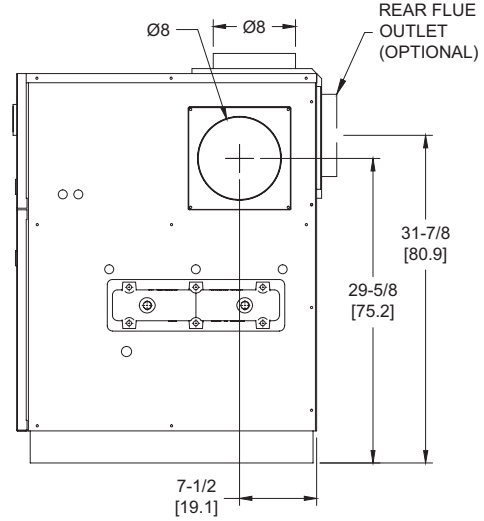

RIGHT VIEW

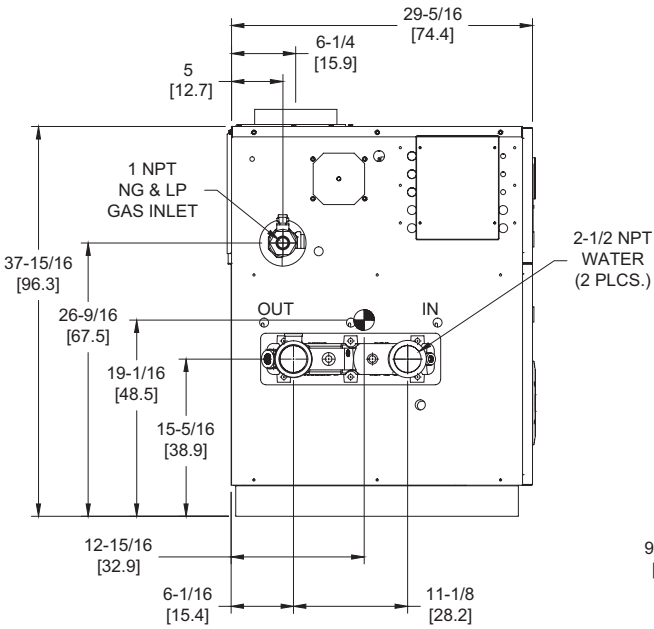

LEFT VIEW

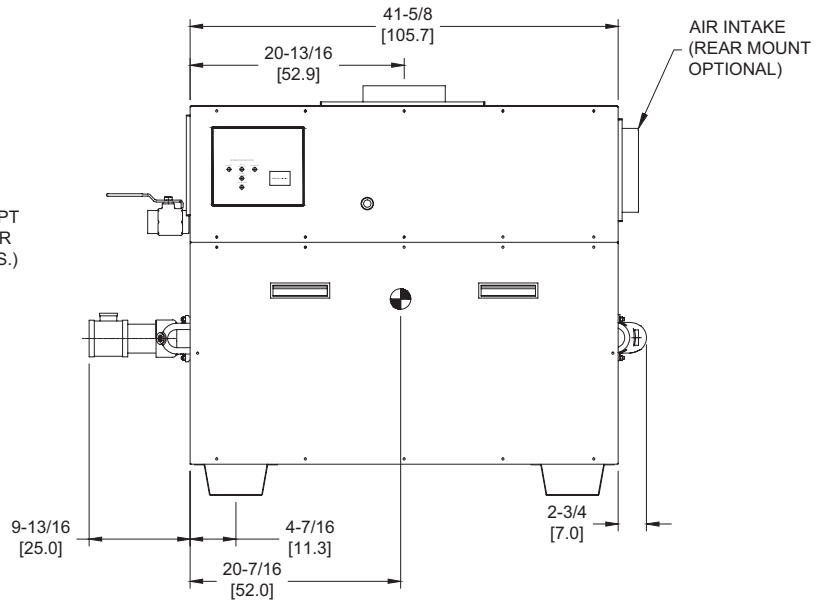

FRONT VIEW

RSUB-17-F

Notes:

1. Dimensions are approximate and should not be used to "rough-in" equipment.
2. Dimensions are subject to change without notice.
3. All dimensions are in inches (cm).
4.  Symbol indicates center of gravity.

BOILER CERTIFIED RATINGS & CAPACITIES

Fuel Type	Natural/Propane Gas	Boiler FLA	5.9*
Input BTU/hr.	750,000 / 220 kW	Min. Gas Pressure Required	7" WC**
Output BTU/hr.	615,000 / 180 kW	Max. Gas Pressure Allowed	14" WC
Electrical Requirements	120VAC/ 1 ph/ 60 hz	Operating Weight	554 lbs. / 252 kg.

BOILER / WATER HEATER TRIM & CONTROLS

Main Gas Valve	Honeywell V8944B 1"	Pilot Valve	Honeywell VR8205Q
Firing Valve	Honeywell B200T1033 1"	Air Switch	Cleveland RSS-495
Safety Valve	Honeywell V48A 1"	Blower Motor	1/4 hp - FLA 5.1
Ignition Control	UTC 1003-61A	Relief Valve - LW	3/4" x 3/4" set @ 125 psi
Operating Control (LB/LW)	Jumo	Relief Valve - LB	3/4" x 3/4" set @ 50 psi
High Limit (LB/LW)	Jumo	Flow Switch	TACO

A.S.M.E.

ASME Sect IV Htg Surface	61.7 Sq. Ft. / 5.73 Sq. M.	Design Data	Max. 160 psig & 250°F
Water Volume	1.7 gal / 6.5 Liters		

* Add circulator amps.

** For incoming gas pressures lower than 7" WC natural or 11" WC propane, consult factory.

BOILER TEMPERATURE RISE / PRESSURE DROP

20°F / 11.1°C				25°F / 13.9°C				30°F / 16.7°C				35°F / 19.4°C			
Flow Rate		Pressure Drop		Flow Rate		Pressure Drop		Flow Rate		Pressure Drop		Flow Rate		Pressure Drop	
GPM	L/s	Ft	kPa	GPM	L/s	Ft	kPa	GPM	L/s	Ft	kPa	GPM	L/s	Ft	kPa
61.5	3.9	1.95	5.7	49.2	3.1	1.29	3.8	41.0	2.6	0.92	2.7	35.1	2.2	0.69	2.0

WATER HEATER HOURLY RECOVERY CAPACITY (GPH & LPH)

40°F	22°C	60°F	33°C	80°F	44°C	100°F	56°C	120°F	67°C	140°F	78°C
1846	6977	1230	4651	923	3488	738	2791	615	2326	527	1993

REP FIRM _____
SUBMITTED BY _____
JOB NAME _____
ARCHITECT _____
ENGINEER _____
CONTRACTOR _____
DATE _____

LCD 750

Category I or Category III Appliance
(see Installation and Operation Manual for venting information)

RBI®
RELIABLE. BOLD. INNOVATIVE.

A Division of Mestek, Inc.
Westfield, MA 01085
(413) 564-5515

LCD 1050

Category I or Category III Appliance

(see Installation and Operation Manual for venting information)

CODE OPTIONS

CSD-1

UTC Lockout/Reset Control
Manual Reset LWCO

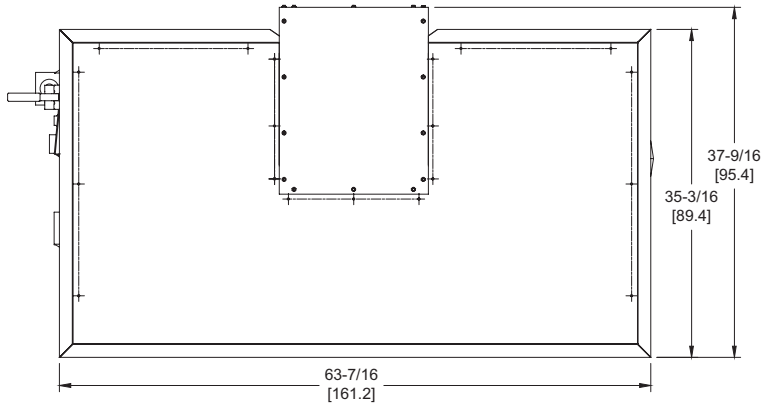

OUTDOOR TOP VIEW

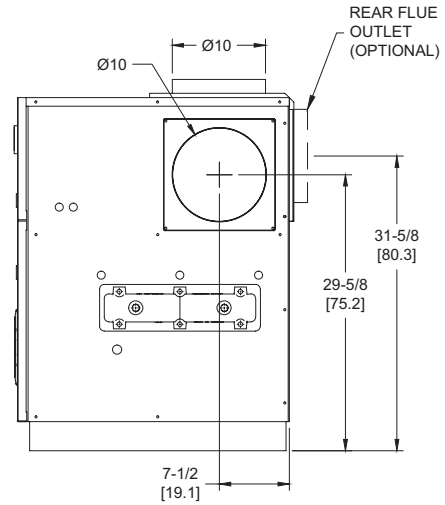

RIGHT VIEW

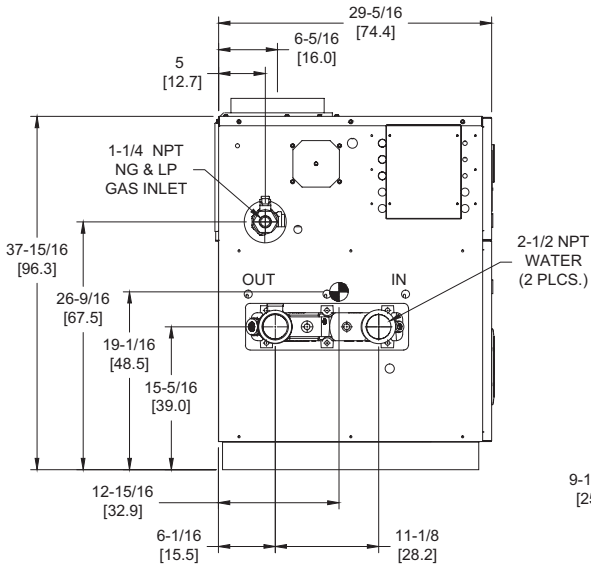

LEFT VIEW

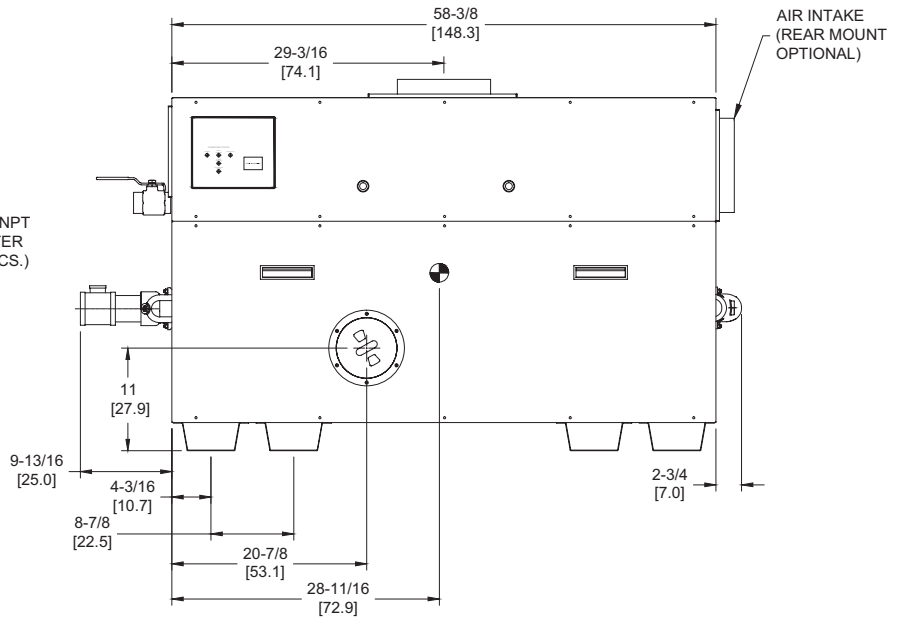

FRONT VIEW

RSUB-19-F

Notes:

1. Dimensions are approximate and should not be used to "rough-in" equipment.
2. Dimensions are subject to change without notice.
3. All dimensions are in inches (cm).
4.  Symbol indicates center of gravity.

BOILER CERTIFIED RATINGS & CAPACITIES

Fuel Type	Natural/Propane Gas	Boiler FLA	11.0*
Input BTU/hr.	1,050,000 / 308 kW	Min. Gas Pressure Required	7" WC**
Output BTU/hr.	861,000 / 252 kW	Max. Gas Pressure Allowed	14" WC
Electrical Requirements	120VAC/ 1 ph/ 60 hz	Operating Weight	752 lbs. / 341 kg.

BOILER / WATER HEATER TRIM & CONTROLS

Main Gas Valve	Honeywell V8944B 1-1/4"	Pilot Valve	Honeywell VR8205Q
Firing Valve	Honeywell B200T1041 1-1/4"	Air Switch	Cleveland RSS-495
Safety Valve	Honeywell V48A 1-1/4"	Blower Motor	1/4 hp - FLA 10.2
Ignition Control	UTC 1003-61A	Relief Valve - LW	3/4" x 3/4" set @ 125 psi
Operating Control (LB/LW)	Jumo	Relief Valve - LB	3/4" x 3/4" set @ 50 psi
High Limit (LB/LW)	Jumo	Flow Switch	TACO

A.S.M.E.

ASME Sect IV Htg Surface	88.1 Sq. Ft. / 8.18 Sq. M.	Design Data	Max. 160 psig & 250°F
Water Volume	2.1 gal / 7.8 Liters		

* Add circulator amps.

** For incoming gas pressures lower than 7" WC natural or 11" WC propane, consult factory.

BOILER TEMPERATURE RISE / PRESSURE DROP

20°F / 11.1°C				25°F / 13.9°C				30°F / 16.7°C				35°F / 19.4°C			
Flow Rate		Pressure Drop		Flow Rate		Pressure Drop		Flow Rate		Pressure Drop		Flow Rate		Pressure Drop	
GPM	L/s	Ft	kPa	GPM	L/s	Ft	kPa	GPM	L/s	Ft	kPa	GPM	L/s	Ft	kPa
86.1	5.4	5.16	15.2	68.9	4.3	3.41	10.1	57.4	3.6	2.44	7.2	49.2	3.1	1.83	5.4

WATER HEATER HOURLY RECOVERY CAPACITY (GPH & LPH)

40°F	22°C	60°F	33°C	80°F	44°C	100°F	56°C	120°F	67°C	140°F	78°C
2587	9780	1725	6520	1294	4890	1035	3912	862	3260	739	2794

<p>REP FIRM _____</p> <p>SUBMITTED BY _____</p> <p>JOB NAME _____</p> <p>ARCHITECT _____</p> <p>ENGINEER _____</p> <p>CONTRACTOR _____</p> <p>DATE _____</p>	<h1 style="margin: 0;">LCD 1050</h1> <p>Category I or Category III Appliance (see Installation and Operation Manual for venting information)</p>  <p>RBI® A Division of Mestek, Inc. Westfield, MA 01085 (413) 564-5515</p> <p><small>RELIABLE. BOLD. INNOVATIVE.</small></p>
---	---

LCD 1200

Category I or Category III Appliance

(see Installation and Operation Manual for venting information)

CODE OPTIONS

CSD-1	UTC Lockout/Reset Control Manual Reset LWCO
--------------	--

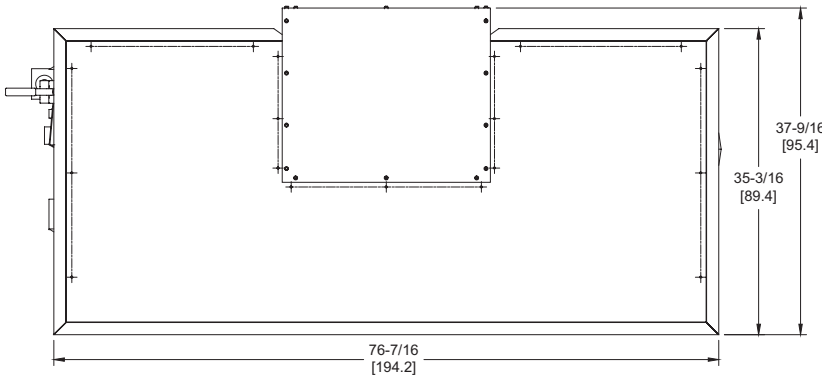

OUTDOOR TOP VIEW

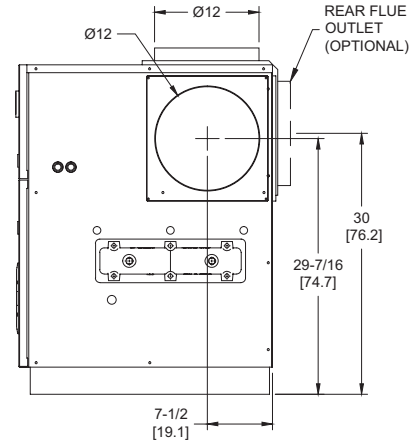

RIGHT VIEW

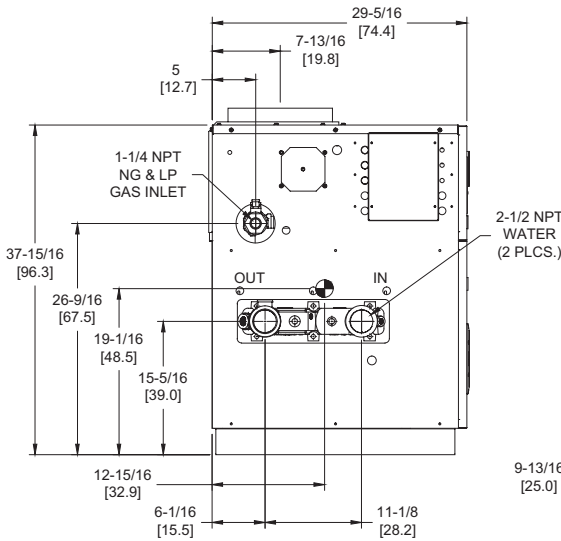

LEFT VIEW

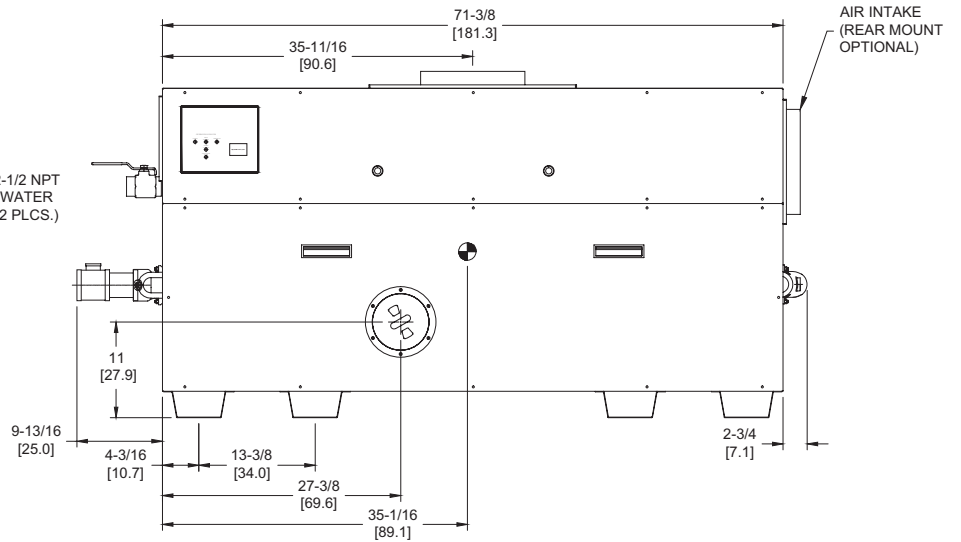

FRONT VIEW

RSUB-20-F

Notes:

1. Dimensions are approximate and should not be used to "rough-in" equipment.
2. Dimensions are subject to change without notice.
3. All dimensions are in inches (cm).
4.  Symbol indicates center of gravity.

BOILER CERTIFIED RATINGS & CAPACITIES

Fuel Type	Natural/Propane Gas	Boiler FLA	11.0*
Input BTU/hr.	1,200,000 / 352 kW	Min. Gas Pressure Required	7" WC**
Output BTU/hr.	984,000 / 288 kW	Max. Gas Pressure Allowed	14" WC
Electrical Requirements	120VAC/ 1 ph/ 60 hz	Operating Weight	781 lbs. / 355 kg.

BOILER / WATER HEATER TRIM & CONTROLS

Main Gas Valve	Honeywell V8944B 1-1/4"	Pilot Valve	Honeywell VR8205Q
Firing Valve	Honeywell B200T1041 1-1/4"	Air Switch	Cleveland RSS-495
Safety Valve	Honeywell V48A 1-1/4"	Blower Motor	(2) 1/4 hp - FLA 10.2
Ignition Control	UTC 1003-61A	Relief Valve - LW	3/4" x 3/4" set @ 125 psi
Operating Control (LB/LW)	Jumo	Relief Valve - LB	1" x 1-1/4" set @ 50 psi
High Limit (LB/LW)	Jumo	Flow Switch	TACO

A.S.M.E.

ASME Sect IV Htg Surface	109.7 Sq. Ft. / 10.19 Sq. M.	Design Data	Max. 160 psig & 250°F
Water Volume	2.3 gal / 8.8 Liters		

* Add circulator amps.

** For incoming gas pressures lower than 7" WC natural or 11" WC propane, consult factory.

BOILER TEMPERATURE RISE / PRESSURE DROP

20°F / 11.1°C				25°F / 13.9°C				30°F / 16.7°C				35°F / 19.4°C			
Flow Rate		Pressure Drop		Flow Rate		Pressure Drop		Flow Rate		Pressure Drop		Flow Rate		Pressure Drop	
GPM	L/s	Ft	kPa	GPM	L/s	Ft	kPa	GPM	L/s	Ft	kPa	GPM	L/s	Ft	kPa
98.4†	6.2†	8.14	24.0	78.7	5.0	5.38	15.9	65.6	4.1	3.84	11.3	56.2	3.5	2.89	8.5

† Flow exceeds recommended maximum use a greater temperature rise or consult manufacturer.
Cupronickel heat exchanger should be considered.

WATER HEATER HOURLY RECOVERY CAPACITY (GPH & LPH)

40°F	22°C	60°F	33°C	80°F	44°C	100°F	56°C	120°F	67°C	140°F	78°C
2960	11190	1974	7460	1480	5595	1184	4476	987	3730	846	3197

REP FIRM _____
SUBMITTED BY _____
JOB NAME _____
ARCHITECT _____
ENGINEER _____
CONTRACTOR _____
DATE _____

LCD 1200

Category I or Category III Appliance
(see Installation and Operation Manual for venting information)

RBI®
RELIABLE. BOLD. INNOVATIVE.

A Division of Mestek, Inc.
Westfield, MA 01085
(413) 564-5515

LCD 1480

Category I or Category III Appliance

(see Installation and Operation Manual for venting information)

CODE OPTIONS

CSD-1	UTC Lockout/Reset Control Manual Reset LWCO
--------------	--

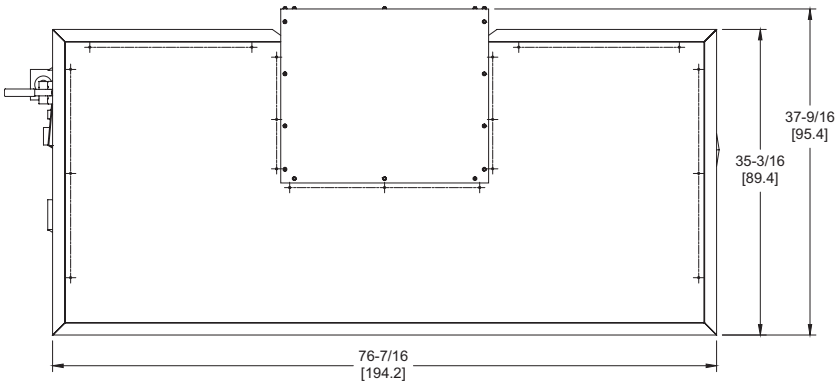

OUTDOOR TOP VIEW

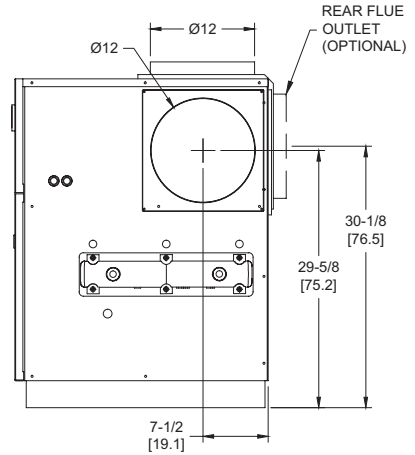

RIGHT VIEW

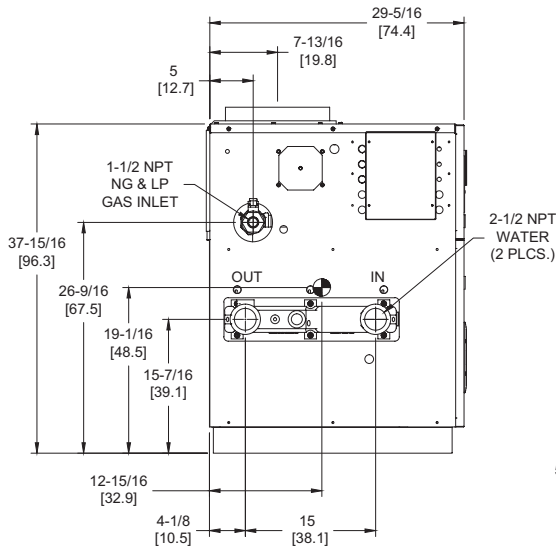

LEFT VIEW

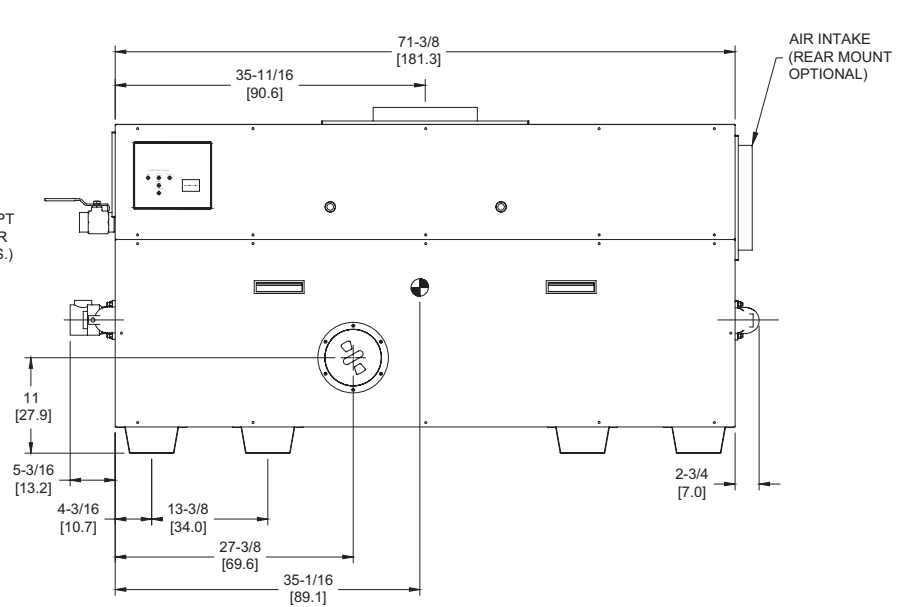

FRONT VIEW

RSUB-21-F

Notes:

1. Dimensions are approximate and should not be used to "rough-in" equipment.
2. Dimensions are subject to change without notice.
3. All dimensions are in inches (cm).
4. Symbol indicates center of gravity.

BOILER CERTIFIED RATINGS & CAPACITIES

Fuel Type	Natural/Propane Gas	Boiler FLA	11.0*
Input BTU/hr.	1,480,000 / 434 kW	Min. Gas Pressure Required	7" WC**
Output BTU/hr.	1,213,600 / 356 kW	Max. Gas Pressure Allowed	14" WC
Electrical Requirements	120VAC/ 1 ph/ 60 hz	Operating Weight	830 lbs. / 377 kg.

BOILER / WATER HEATER TRIM & CONTROLS

Main Gas Valve	Honeywell V8944B 1-1/2"	Pilot Valve	Honeywell VR8205Q
Firing Valve	Honeywell B200T1058 1-1/2"	Air Switch	Cleveland RSS-495
Safety Valve	Honeywell V48A 1-1/2"	Blower Motor	(2) 1/4 hp - FLA 10.2
Ignition Control	UTC 1003-61A	Relief Valve - LW	3/4" x 3/4" set @ 125 psi
Operating Control (LB/LW)	Jumo	Relief Valve - LB	1" x 1-1/4" set @ 50 psi
High Limit (LB/LW)	Jumo	Flow Switch	TACO

A.S.M.E.

ASME Sect IV Htg Surface	137 Sq. Ft. / 12.73 Sq. M.	Design Data	Max. 160 psig & 250°F
Water Volume	4.8 gal / 18.2 Liters		

* Add circulator amps.

** For incoming gas pressures lower than 7" WC natural or 11" WC propane, consult factory.

BOILER TEMPERATURE RISE / PRESSURE DROP

20°F / 11.1°C				25°F / 13.9°C				30°F / 16.7°C				35°F / 19.4°C			
Flow Rate		Pressure Drop		Flow Rate		Pressure Drop		Flow Rate		Pressure Drop		Flow Rate		Pressure Drop	
GPM	L/s	Ft	kPa	GPM	L/s	Ft	kPa	GPM	L/s	Ft	kPa	GPM	L/s	Ft	kPa
121.4†	7.7†	7.94	23.4	97.1	6.1	5.25	15.5	80.9	5.1	3.75	11.0	69.3	4.4	2.82	8.3

† Flow exceeds recommended maximum use a greater temperature rise or consult manufacturer.
Cupronickel heat exchanger should be considered.

WATER HEATER HOURLY RECOVERY CAPACITY (GPH & LPH)

40°F	22°C	60°F	33°C	80°F	44°C	100°F	56°C	120°F	67°C	140°F	78°C
3656	13818	2437	9212	1828	6909	1462	5527	1219	4606	1044	3948

REP FIRM _____
SUBMITTED BY _____
JOB NAME _____
ARCHITECT _____
ENGINEER _____
CONTRACTOR _____
DATE _____

LCD 1480

Category I or Category III Appliance
 (see Installation and Operation Manual for venting information)

RBI®
 RELIABLE. BOLD. INNOVATIVE.

A Division of Mestek, Inc.
 Westfield, MA 01085
 (413) 564-5515

LCD 1650

Category I or Category III Appliance

(see Installation and Operation Manual for venting information)

CODE OPTIONS

CSD-1

UTC Lockout/Reset Control
Manual Reset LWCO

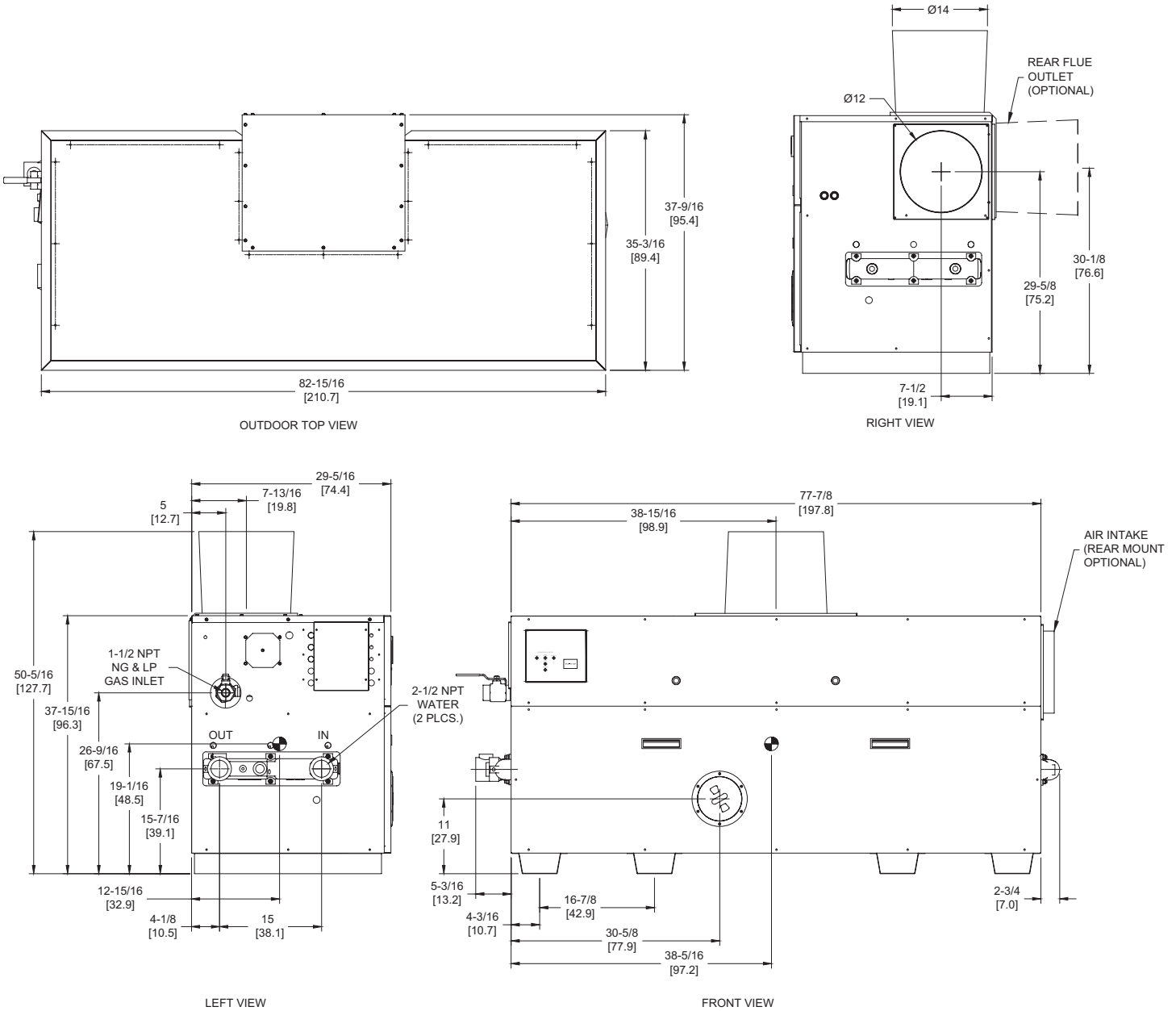

RSUB-22-F

Notes:

1. Dimensions are approximate and should not be used to "rough-in" equipment.
2. Dimensions are subject to change without notice.
3. All dimensions are in inches (cm).
4. Symbol indicates center of gravity.

BOILER CERTIFIED RATINGS & CAPACITIES

Fuel Type	Natural/Propane Gas	Boiler FLA	11.0*
Input BTU/hr.	1,650,000 / 483 kW	Min. Gas Pressure Required	7" WC**
Output BTU/hr.	1,353,000 / 396 kW	Max. Gas Pressure Allowed	14" WC
Electrical Requirements	120VAC/ 1 ph/ 60 hz	Operating Weight	906 lbs. / 411 kg.

BOILER / WATER HEATER TRIM & CONTROLS

Main Gas Valve	Honeywell V8944B 1-1/2"	Pilot Valve	Honeywell VR8205Q
Firing Valve	Honeywell B200T1058 1-1/2"	Air Switch	Cleveland RSS-495
Safety Valve	Honeywell V48A 1-1/2"	Blower Motor	(2) 1/4 hp - FLA 10.2
Ignition Control	UTC 1003-61A	Relief Valve - LW	3/4" x 3/4" set @ 125 psi
Operating Control (LB/LW)	Jumo	Relief Valve - LB	1" x 1- 1/4" set @ 50 psi
High Limit (LB/LW)	Jumo	Flow Switch	TACO

A.S.M.E.

ASME Sect IV Htg Surface	149 Sq. Ft. / 13.84 Sq. M.	Design Data	Max. 160 psig & 250°F
Water Volume	4.9 gal / 18.6 Liters		

* Add circulator amps.

** For incoming gas pressures lower than 7" WC natural or 11" WC propane, consult factory.

BOILER TEMPERATURE RISE / PRESSURE DROP

25°F / 13.9°C				30°F / 16.7°C				35°F / 19.4°C			
Flow Rate		Pressure Drop		Flow Rate		Pressure Drop		Flow Rate		Pressure Drop	
GPM	L/s	Ft	kPa	GPM	L/s	Ft	kPa	GPM	L/s	Ft	kPa
108.2	6.8	7.02	20.7	90.2	5.7	5.01	14.8	77.3	4.9	3.77	11.1

WATER HEATER HOURLY RECOVERY CAPACITY (GPH & LPH)

40°F	22°C	60°F	33°C	80°F	44°C	100°F	56°C	120°F	67°C	140°F	78°C
4075	15405	2717	10270	2038	7703	1630	6162	1358	5135	1164	4402

REP FIRM _____
SUBMITTED BY _____
JOB NAME _____
ARCHITECT _____
ENGINEER _____
CONTRACTOR _____
DATE _____

LCD 1650

Category I or Category III Appliance
(see Installation and Operation Manual for venting information)

RBI®
RELIABLE. BOLD. INNOVATIVE.

A Division of Mestek, Inc.
Westfield, MA 01085
(413) 564-5515

LCD 1970

Category I or Category III Appliance
(see Installation and Operation Manual for venting information)

CODE OPTIONS

CSD-1	UTC Lockout/Reset Control Manual Reset LWCO
--------------	--

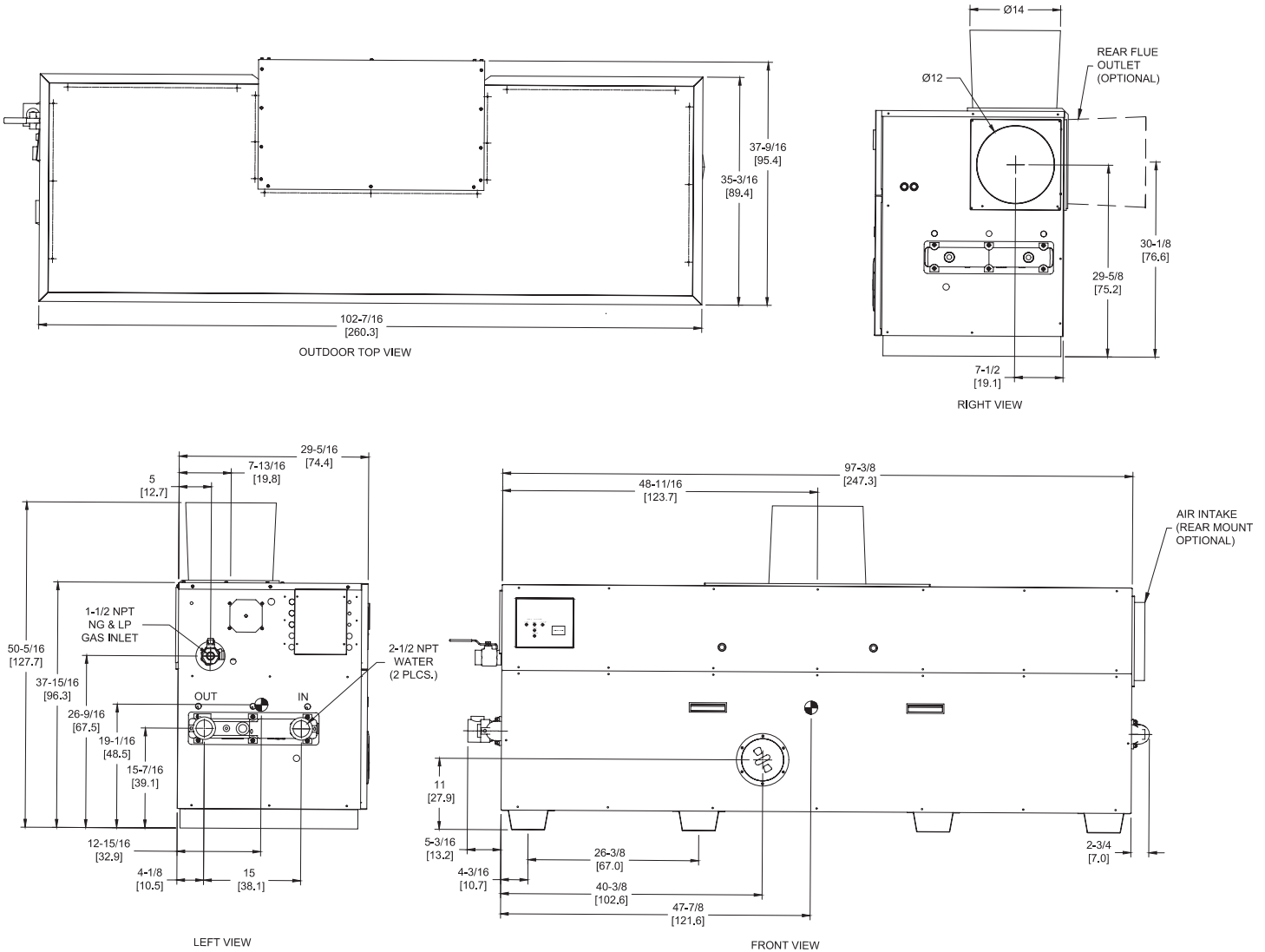

RSUB-23-F

Notes:

1. Dimensions are approximate and should not be used to "rough-in" equipment.
2. Dimensions are subject to change without notice.
3. All dimensions are in inches (cm).
4. Symbol indicates center of gravity.

BOILER CERTIFIED RATINGS & CAPACITIES

Fuel Type	Natural/Propane Gas	Boiler FLA	11.0*
Input BTU/hr.	1,970,000 / 577 kW	Min. Gas Pressure Required	7" WC**
Output BTU/hr.	1,615,400 / 473 kW	Max. Gas Pressure Allowed	14" WC
Electrical Requirements	120VAC/ 1 ph/ 60 hz	Operating Weight	1073 lbs. / 487 kg.

BOILER / WATER HEATER TRIM & CONTROLS

Main Gas Valve	Honeywell V8944B 1-1/2"	Pilot Valve	Honeywell VR8205Q
Firing Valve	Honeywell B200T1058 1-1/2"	Air Switch	Cleveland RSS-495
Safety Valve	Honeywell V48A 1-1/2"	Blower Motor	(2) 1/4 hp - FLA 10.2
Ignition Control	UTC 1003-61A	Relief Valve - LW	3/4" x 3/4" set @ 125 psi
Operating Control (LB/LW)	Jumo	Relief Valve - LB	1" x 1-1/4" set @ 50 psi
High Limit (LB/LW)	Jumo	Flow Switch	TACO

A.S.M.E.

ASME Sect IV Htg Surface	189 Sq. Ft. / 17.56 Sq. M.	Design Data	Max. 160 psig & 250°F
Water Volume	5.4 gal / 20.4 Liters		

* Add circulator amps.

** For incoming gas pressures lower than 7" WC natural or 11" WC propane, consult factory.

BOILER TEMPERATURE RISE / PRESSURE DROP

30°F / 16.7°C				35°F / 19.4°C			
Flow Rate		Pressure Drop		Flow Rate		Pressure Drop	
GPM	L/s	Ft	kPa	GPM	L/s	Ft	kPa
107.7	6.8	8.75	25.8	92.3	5.8	6.58	19.4

WATER HEATER HOURLY RECOVERY CAPACITY (GPH & LPH)

40°F	22°C	60°F	33°C	80°F	44°C	100°F	56°C	120°F	67°C	140°F	78°C
4872	18415	3248	12277	2436	9208	1949	7366	1624	6138	1392	5262

REP FIRM	_____
SUBMITTED BY	_____
JOB NAME	_____
ARCHITECT	_____
ENGINEER	_____
CONTRACTOR	_____
DATE	_____

LCD 1970

Category I or Category III Appliance
(see Installation and Operation Manual for venting information)

RBI®
RELIABLE. BOLD. INNOVATIVE.

A Division of Mestek, Inc.
Westfield, MA 01085
(413) 564-5515

LCD 2300

Category I or Category III Appliance

(see Installation and Operation Manual for venting information)

CODE OPTIONS

CSD-1	UTC Lockout/Reset Control Manual Reset LWCO
--------------	--

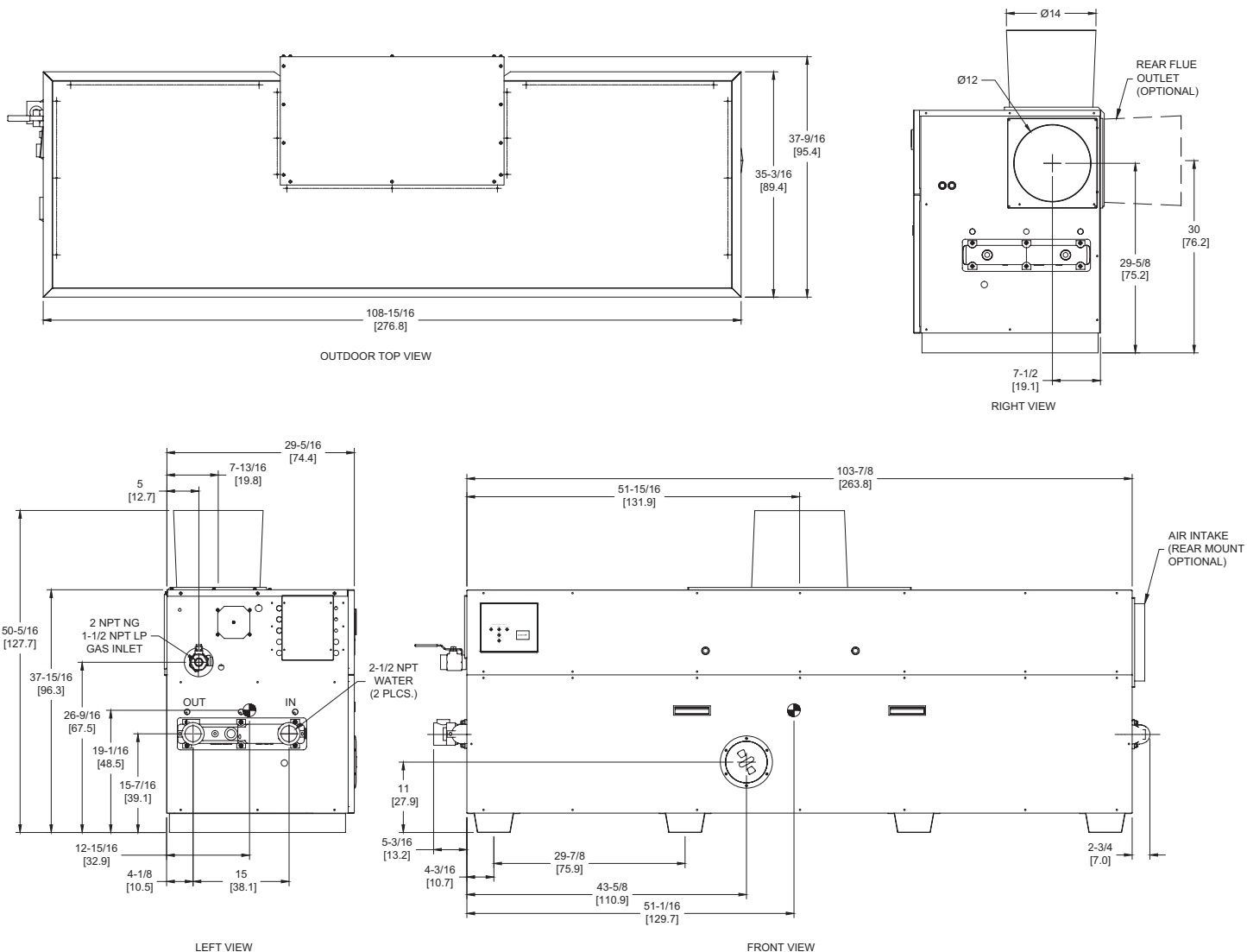

RSUB-24-F

Notes:

1. Dimensions are approximate and should not be used to "rough-in" equipment.
2. Dimensions are subject to change without notice.
3. All dimensions are in inches (cm).
4. Symbol indicates center of gravity.

BOILER CERTIFIED RATINGS & CAPACITIES

Fuel Type	Natural/Propane Gas	Boiler FLA	12.5*
Input BTU/hr.	2,300,000 / 674 kW	Min. Gas Pressure Required	7" WC**
Output BTU/hr.	1,886,000 / 553 kW	Max. Gas Pressure Allowed	14" WC
Electrical Requirements	120VAC/ 1 ph/ 60 hz	Operating Weight	1085 lbs. / 493 kg.

BOILER / WATER HEATER TRIM & CONTROLS

Main Gas Valve	Honeywell V8944B 2"	Pilot Valve	Honeywell VR8205Q
Firing Valve	Honeywell B200T1066 2"	Air Switch	Cleveland RSS-495
Safety Valve	Honeywell V48A 2"	Blower Motor	(2) 1/4 hp (1) 1/5 hp - FLA 13.2
Ignition Control	UTC 1003-61A	Relief Valve - LW	3/4" x 3/4" set @ 125 psi
Operating Control (LB/LW)	Jumo	Relief Valve - LB	1" x 1-1/4" set @ 50 psi
High Limit (LB/LW)	Jumo	Flow Switch	TACO

A.S.M.E.

ASME Sect IV Htg Surface	202 Sq. Ft. / 18.77 Sq. M.	Design Data	Max. 160 psig & 250°F
Water Volume	5.6 gal / 21.4 Liters		

* Add circulator amps.

** For incoming gas pressures lower than 7" WC natural or 11" WC propane, consult factory.

BOILER TEMPERATURE RISE / PRESSURE DROP

30°F / 16.7°C				35°F / 19.4°C			
Flow Rate		Pressure Drop		Flow Rate		Pressure Drop	
GPM	L/s	Ft	kPa	GPM	L/s	Ft	kPa
125.7†	7.9†	12.45	36.7	107.8	6.8	9.36	27.6

† Flow exceeds recommended maximum use a greater temperature rise or consult manufacturer.
Cupronickel heat exchanger should be considered.

WATER HEATER HOURLY RECOVERY CAPACITY (GPH & LPH)

40°F	22°C	60°F	33°C	80°F	44°C	100°F	56°C	120°F	67°C	140°F	78°C
5695	21526	3797	14351	2847	10763	2278	8611	1898	7175	1627	6150

REP FIRM _____
SUBMITTED BY _____
JOB NAME _____
ARCHITECT _____
ENGINEER _____
CONTRACTOR _____
DATE _____

LCD 2300

Category I or Category III Appliance
 (see Installation and Operation Manual for venting information)

RBI®
 RELIABLE. BOLD. INNOVATIVE.

A Division of Mestek, Inc.
 Westfield, MA 01085
 (413) 564-5515